

ENERGY MECHANIX INC.
 P.O. BOX 2397
 ROCKLIN, CA 95677
 TELEPHONE: 650-595-1662

NES SERIES 9000X
 CO SYSTEM FIELD WIRING



JOB NUMBER
 N/A
 Apr 3, 2023
 SCALE: N/A

W.1

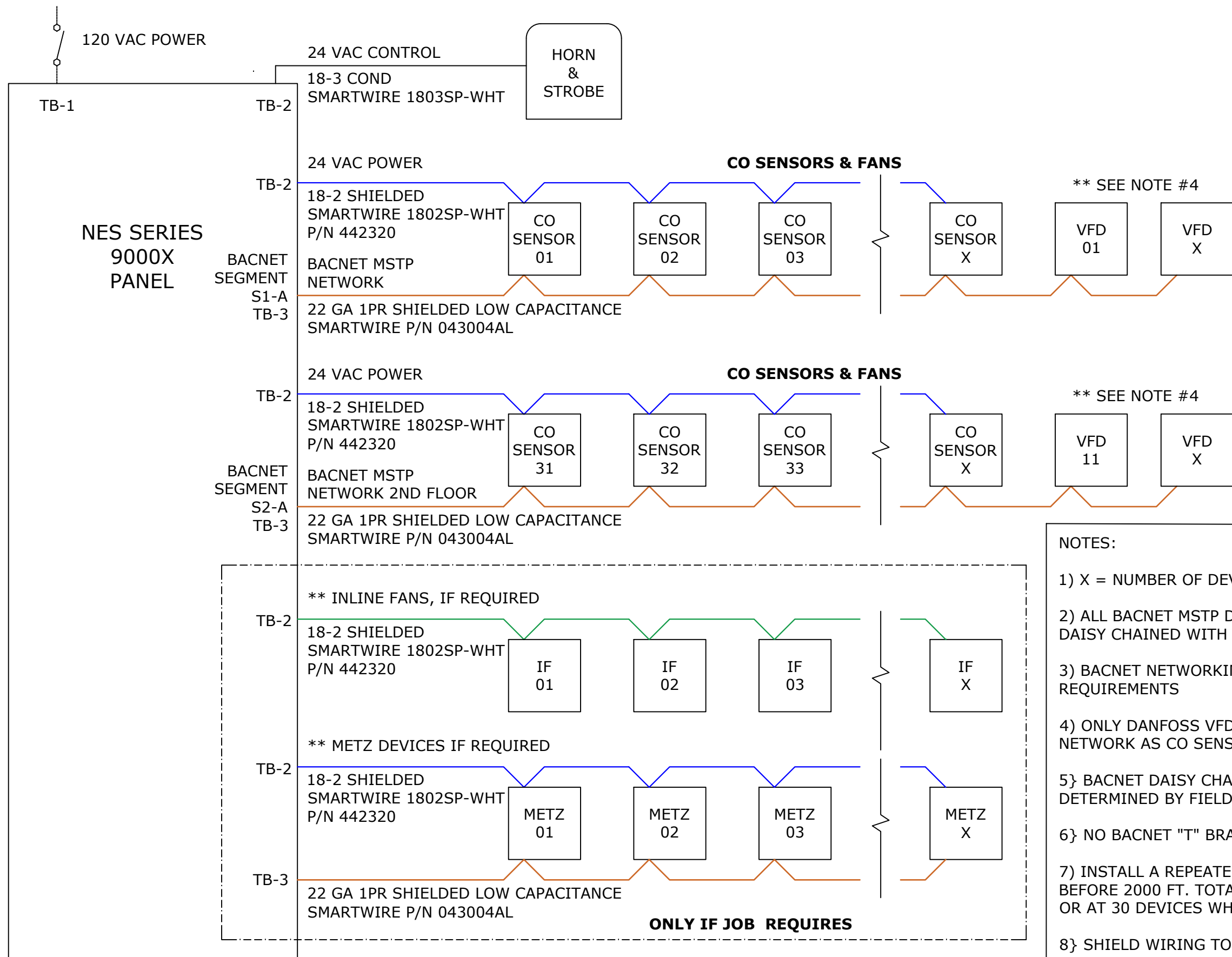

- NOTES:
- 1) X = NUMBER OF DEVICES AS PER JOB SPECS.
 - 2) ALL BACNET MSTP DEVICES ARE TO BE SERIALLY DAISY CHAINED WITH UNIQUE ADDRESSING.
 - 3) BACNET NETWORKING DETERMINED BY JOB REQUIREMENTS
 - 4) ONLY DANFOSS VFD'S ALLOWED ON SAME NETWORK AS CO SENSORS
 - 5) BACNET DAISY CHAIN ORDER TO BE DETERMINED BY FIELD CONDITIONS.
 - 6) NO BACNET "T" BRANCHES ALLOWED.
 - 7) INSTALL A REPEATER AT NEAREST CO SENSOR BEFORE 2000 FT. TOTAL WIRE SEGMENT LENGTH OR AT 30 DEVICES WHICHEVER COMES FIRST.
 - 8) SHIELD WIRING TO BE CONNECTED THOUGH IF NO TERMINALS AVAILABLE AT DEVICES.
 - 9) CO SENSOR NUMBERS AND FAN IDENTIFIER NUMBERS AS PER JOB REQUIREMENTS.

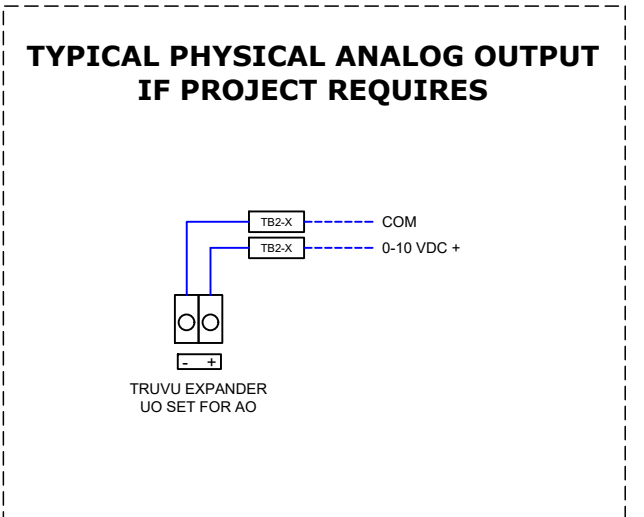
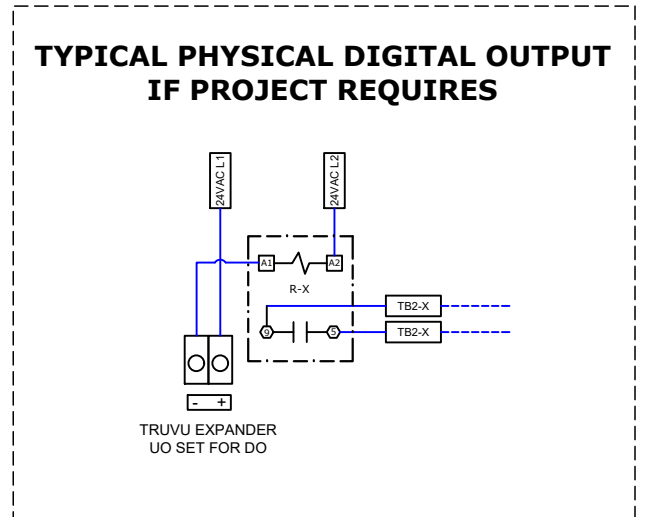
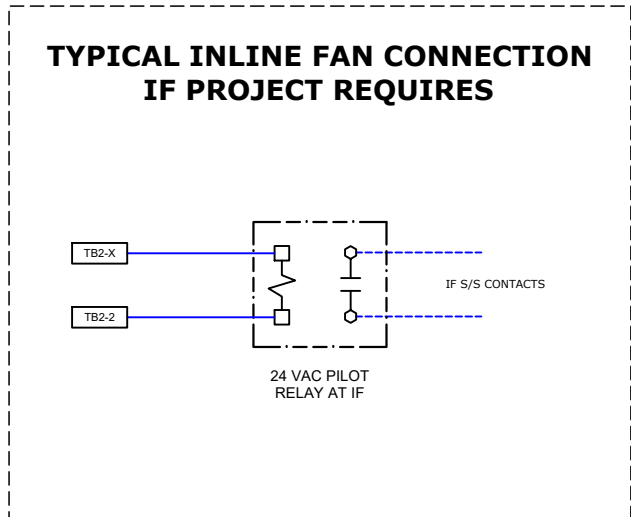
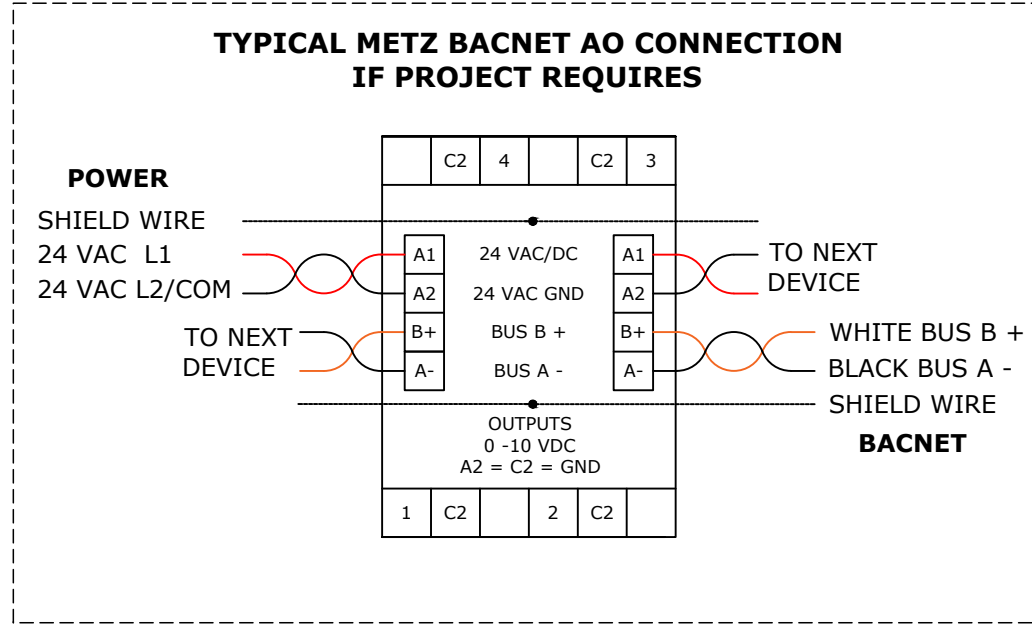
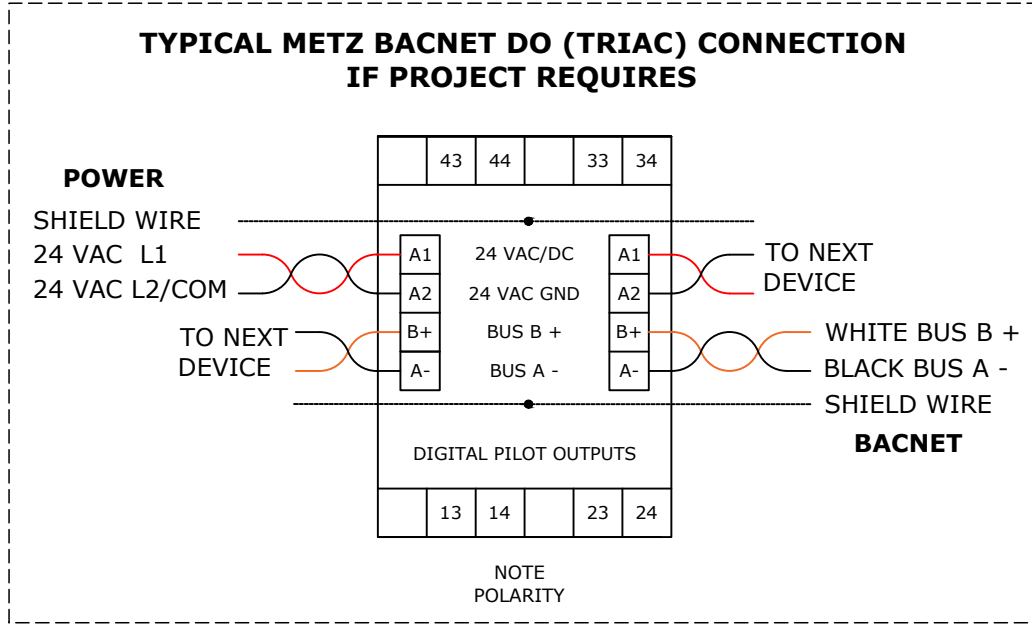
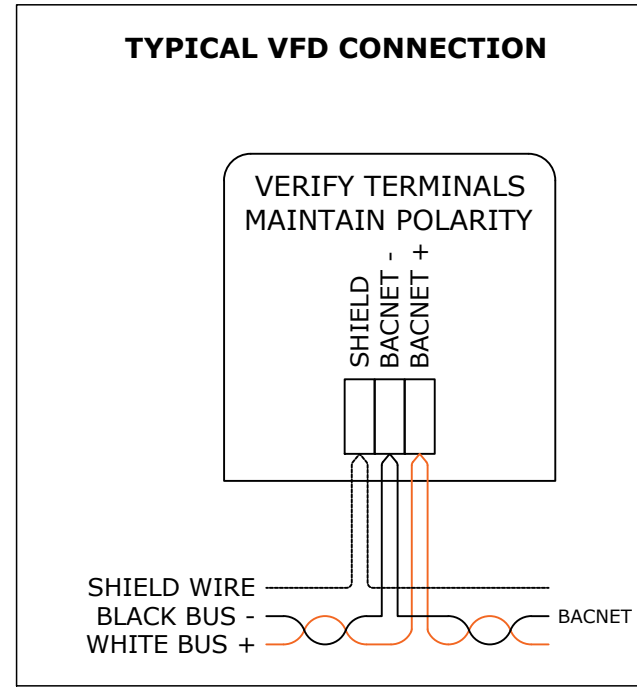
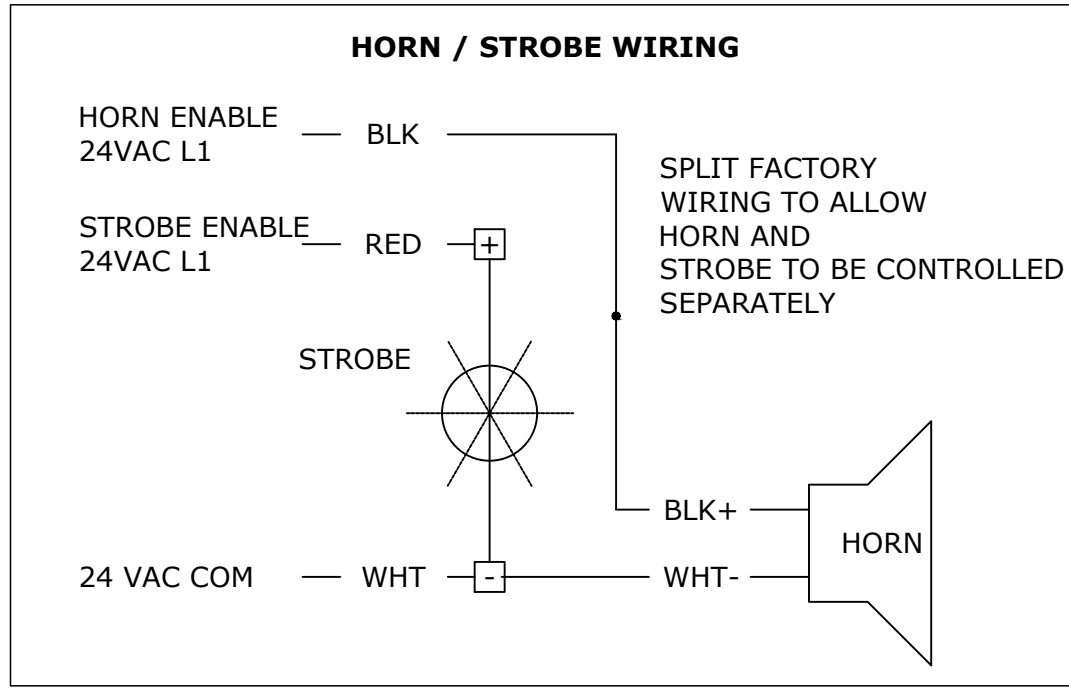
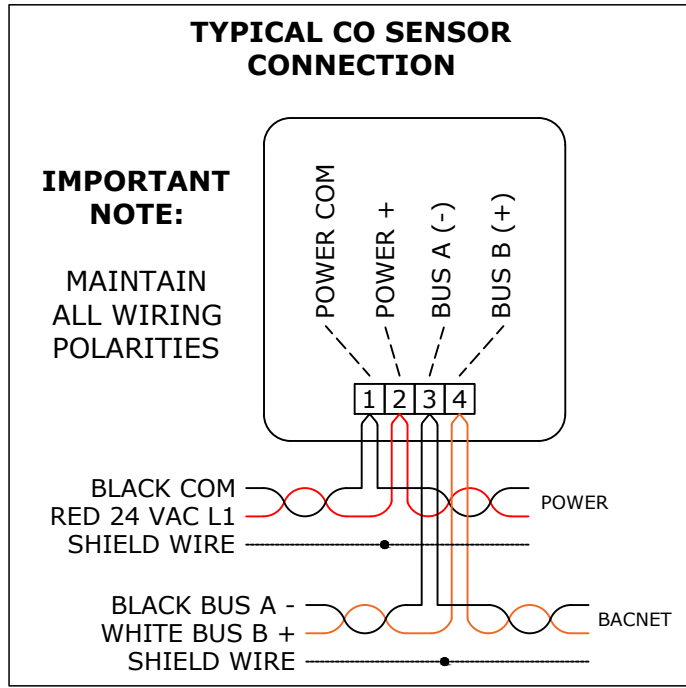

NOTES:

1. All terminal numbers to be verified with specific project drawings.
2. All output numbers to be verified with specific project drawings.
3. Maintain polarity with all Bacnet and 24 VAC power supplies.